

## SR71-BLACKBIRD – Carbon excellence without compromise

Designed with Japanese Toray T700 carbon fiber and reinforced with T1000 in critical areas, the SR71-BLACKBIRD frame delivers exceptional stiffness while maintaining a controlled weight.

The combination of 3K woven carbon and unidirectional UD carbon creates a structure that is ultra-rigid where performance demands it, and intentionally more flexible in strategic zones to absorb impacts, reduce vibrations, and limit the risk of sudden failure.

This controlled flexibility enhances riding comfort and significantly increases long-term durability.

Advanced fiber orientation at 0° / 20° / 45°, with up to 9 reinforcement layers, ensures stability, precision, and reliability even under extreme loads.

The frame features a patented half-moon rear dropout system, providing:

- perfect wheel alignment,
  - superior lateral stiffness,
  - fast and secure wheel removal,
  - precise and consistent chain tension
- Co-molded aluminum inserts guarantee long-lasting mechanical accuracy.

**Lighter. Stiffer. Smarter.**

A frame engineered for top-level performance.

### Key Features

- Patented 'Semi-Circle System': Provides a 50mm adjustment range across 6 positions for increased rigidity and precise setup without needing to adjust the rear wheel (4 positions in 10mm for Junior and Expert sizes)
- Axle Compatibility: Works with 10mm (6 positions) or 15mm axles (4 positions – not compatible for junior and expert sizes). Available as an option.
- Unbreakable Strength: The frame is reinforced at the dropout with 7075 aluminum for exceptional durability.
- New Chain Tensioner: Ensures precise horizontal tension for a long-lasting chain.
- Internal Cable Management: Features plastic guides for a clean and secure cable routing.
- Maximum Gear Ratio: 52×18

### Sold With the Frame

Chain tensioner

Quick-release seat clamp

Disc brake bracket

Plate for 10mm screw-on axle

### Option

Plate for 15mm screw-on axle

Bottom Bracket Pressfit 41mm

Headset integrated 1-1/8 - 1.5

MARSHAL RACING

380 petite route de Marseille – 83470 SAINT MAXIMIN LA SAINTE BAUME

www.bmx-marshal.com

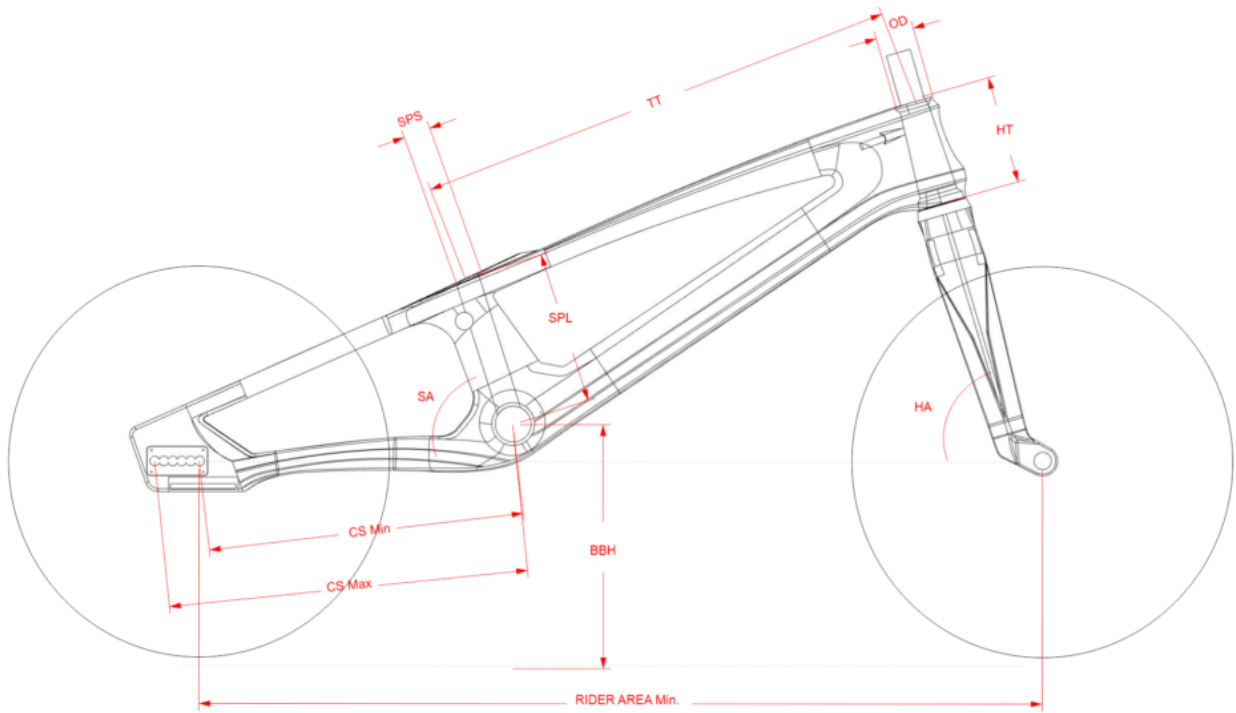

Weight frame PRO XL = 1,560 Kg (+/- 2%) | 3.307 lbs (+/- 2%)

Tailles 20"	RIDER AREA Min	TT	CS min	CS max	BBH	SA	HA	OD	SPL	SP SIZE	HT	BB Type
Junior light		18.8" 478 mm	320 mm	352 mm	276 mm	70°	73°	intégré conique OD 1-1/8" - 1,5"	182 mm	27,2 mm	115mm	PRESSFIT
Expert +		19.7" 500 mm	320 mm	352 mm	276 mm	70°	73°	intégré conique OD 1-1/8" - 1,5"	182 mm	27,2 mm	115mm	PRESSFIT
Pro		20.5" 520,7 mm	360 mm	410 mm	11,5 292 mm	72,5°	74°	intégré conique OD 1-1/8" - 1,5"	175mm	27,2 mm	120mm	PRESSFIT
Pro XL	948 mm	21" 533,5 mm	360 mm	410 mm	11,5 292 mm	72,5°	74°	intégré conique OD 1-1/8" - 1,5"	175mm	27,2 mm	120mm	PRESSFIT
Pro XXL	961 mm	21.5" 546 mm	360 mm	410 mm	11,5 292 mm	72,5°	74°	intégré conique OD 1-1/8" - 1,5"	175mm	27,2 mm	120mm	PRESSFIT
Pro XXXL	989 mm	22" 558 mm	375 mm	425 mm	11,5 292 mm	72,5°	74°	intégré conique OD 1-1/8" - 1,5"	175mm	27,2 mm	120mm	PRESSFIT
Pro XXXXL	1002 mm	22,5" 570 mm	375 mm	425 mm	11,5 292 mm	72,5°	74°	intégré conique OD 1-1/8" - 1,5"	175mm	27,2 mm	120mm	PRESSFIT
Tailles 24"	RIDER AREA Min	TT	CS min	CS min	BBH	SA	HA	OD	SPL	SP SIZE	HT	BB Type
Cruiser	956 mm	21,25" 540 mm	380 mm	430 mm	12 305 mm	69,5°	73°	intégré conique OD 1-1/8" - 1,5"	232 mm	27,2 mm	120mm	PRESSFIT
Cruiser XL	974 mm	22" 558 mm	380 mm	430 mm	12 305 mm	69,5°	73°	intégré conique OD 1-1/8" - 1,5"	232 mm	27,2 mm	120mm	PRESSFIT